

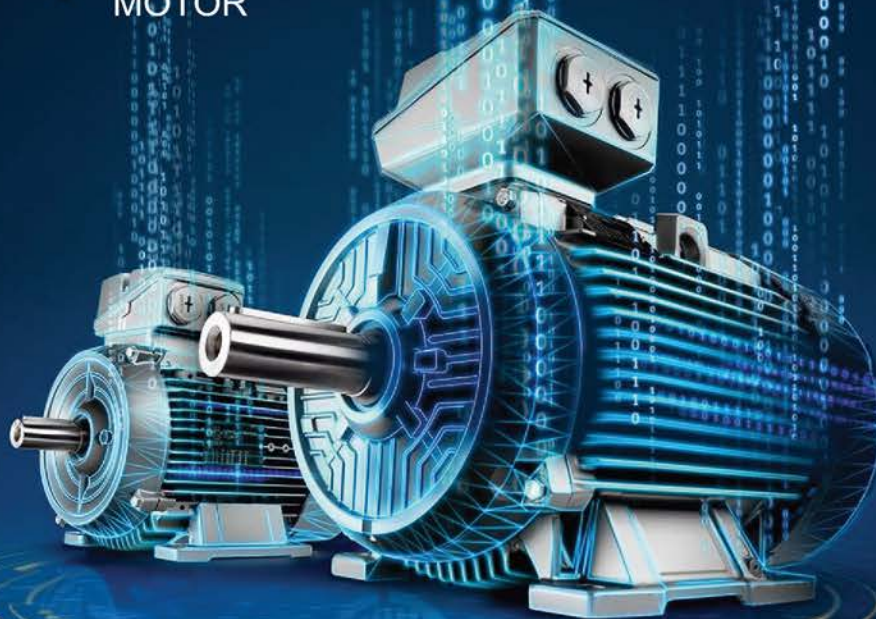

INDUCTION MOTOR



Manufacturing Of All Type Of
3 Phase & Single Phase Electrical Motor



INDUCTION MOTOR

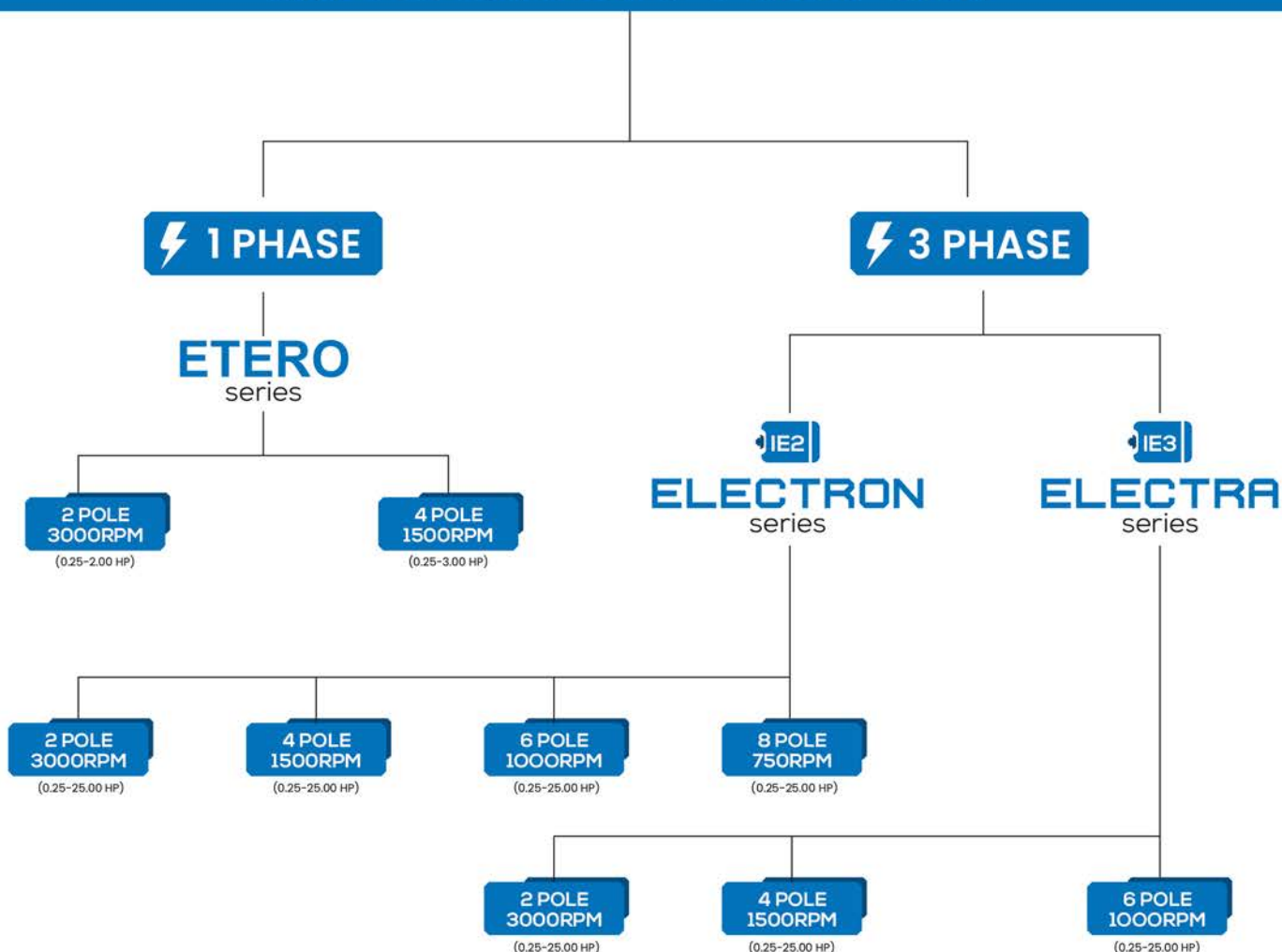

INDUCTION MOTOR

IE2 3 PHASE

ELECTRON series



RANGE AVAILABLE

OUTPUT : 0.18 kW to 18.5 kW (0.25 HP to 25.0 HP)

FRAME SIZE : 63 to 225 S

POLES : 2 to 8

TECHNICAL SPECIFICATION

STANDARD PRODUCT

OPTIONS AVAILABLE

	STANDARD PRODUCT	OPTIONS AVAILABLE
Degree of Protection	IP 55	IP 56
Insulation Class	F	H
Temperature Rise	Limited to class B	F
Rated Voltage	415 Volt (± 10 %)	230 Volt
Rated Frequency	50 Hz (± 5 %)	60 Hz
Enclosure	Totally Enclosed Fan Cooled (TEFC)	-
Mounting	Foot, Flange (B - Type & C- Type)	it's Combination (refer Mounting details for Mounting arrangement)
Duty	S1	-
Maximum Ambient Temp.	40° C	50° C
Altitude	Up to 1000 MASL(Meter above Sea Level)	-
Cooling Method	IC 411	IC 410
Paint Colour	Da Gray	on Request
Fan Cover	Sheet Metal	-
Terminal Box Position	Top	Left hand side(LHS), Right hand side (RHS)
Shaft Extension	Single	Duel
Brake provision	-	on Request

Note: On request of optional features, Minimum Order Quantity may be applicable & Lead time may vary from standard product, for more information please contact our branch Office.

THREE PHASE INDUCTION MOTORS

TECHNICAL SPECIFICATIONS

Efficiency Class : IE2	Enclosure : TEFC	Insulation Class : F
Voltage : 415 (±10 %) V	Duty : S1	Temp. Rise : Limited to class B
Frequency : 50 (±5 %) Hz	Cooling : IC 411	Ambient Temperature : 40°C
	Degree of protections : IP 55	



Combined Variation of Voltage & Frequency : ±10 %

2 Pole / 3000 RPM

MOTOR RATING		FRAME SIZE	RATED SPEED (RPM)	RATED CURRENT (AMP.)	RATED TORQUE (KG.M.)	EFFICIENCY			POWER FACTOR			STARTING CURRENT % OF RATED CURRENT	STARTING TORQUE % OF RATED TORQUE	PULL OUT TORQUE % OF RATED TORQUE	GD ² (KGM ²)
kW	HP					FL	¾L	½L	FL	¾L	½L				
0.18	0.25	63	2780	0.800	0.06	60.40	59.00	57.00	0.60	0.53	0.49	550	200	200	0.00130
0.25	0.33	63	2790	0.900	0.09	64.80	64.00	62.00	0.65	0.58	0.54	550	210	225	0.00150
0.37	0.50	71	2800	0.990	0.13	69.50	69.50	67.00	0.77	0.70	0.62	500	220	275	0.00190
0.55	0.75	71	2810	1.400	0.19	74.10	74.00	71.50	0.78	0.73	0.65	500	230	275	0.00190
0.75	1.00	80	2830	1.780	0.26	77.40	76.50	73.00	0.82	0.82	0.78	550	240	250	0.00360
1.10	1.50	80	2835	2.430	0.38	79.60	79.00	74.00	0.80	0.75	0.62	600	260	300	0.00450
1.50	2.00	90S	2840	3.160	0.51	81.30	81.00	78.00	0.82	0.78	0.68	650	250	300	0.00900
2.20	3.00	90L	2850	4.560	0.75	83.20	82.75	81.00	0.80	0.78	0.68	675	250	300	0.01100
3.00	4.00	100L	2875	6.880	1.02	85.50	85.00	83.00	0.82	0.79	0.72	700	250	275	0.02000
3.70	5.00	100L	2880	6.950	1.25	85.50	85.00	84.00	0.86	0.81	0.72	675	275	275	0.02200
5.50	7.50	132S	2885	9.870	1.86	87.00	85.80	82.00	0.88	0.80	0.78	650	250	275	0.08000
7.50	10.00	132S	2895	13.450	2.52	88.10	87.00	84.50	0.89	0.86	0.80	650	250	275	0.09000
9.30	12.50	160M	2915	17.400	3.11	89.40	88.00	86.00	0.88	0.84	0.80	650	250	250	0.15000
11.00	15.00	160M	2925	20.000	3.66	89.40	89.00	88.50	0.88	0.83	0.78	650	220	250	0.17000
15.00	20.00	160M	2925	27.000	4.99	90.30	90.00	88.50	0.87	0.85	0.82	650	210	250	0.19000
18.50	25.00	160L	2930	32.800	6.15	90.90	90.70	90.00	0.88	0.86	0.84	700	200	250	0.26000



TECHNICAL SPECIFICATIONS

Efficiency Class : IE2	Enclosure : TEFC	Insulation Class : F
Voltage : 415 (±10 %) V	Duty : S1	Temp. Rise : Limited to class B
Frequency : 50 (±5 %) Hz	Cooling : IC 411	Ambient Temperature : 40°C
	Degree of protections : IP 55	

4 Pole / 1500 RPM

Combined Variation of Voltage & Frequency : ±10 %

MOTOR RATING		FRAME SIZE	RATED SPEED (RPM)	RATED CURRENT (AMP.)	RATED TORQUE (KG.M.)	EFFICIENCY			POWER FACTOR			STARTING CURRENT % OF RATED CURRENT	STARTING TORQUE % OF RATED TORQUE	PULL OUT TORQUE % OF RATED TORQUE	GD ² (KGM ²)
kW	HP					FL	¾L	½L	FL	¾L	½L				
0.18	0.25	63	1350	0.800	0.13	64.70	62.00	59.00	0.60	0.56	0.50	550	200	200	0.00220
0.25	0.33	71	1360	0.900	0.18	68.50	66.50	62.00	0.65	0.61	0.52	550	210	210	0.00250
0.37	0.50	71	1375	1.120	0.26	72.70	70.00	65.00	0.71	0.68	0.60	550	225	250	0.00300
0.55	0.75	80	1410	1.460	0.38	77.10	75.00	68.00	0.73	0.70	0.68	550	250	275	0.00700
0.75	1.00	80	1425	1.900	0.51	79.60	79.00	74.00	0.75	0.72	0.65	500	240	275	0.00820
1.10	1.50	90S	1430	2.700	0.75	81.40	81.00	78.00	0.78	0.75	0.73	550	250	275	0.01500
1.50	2.00	90L	1440	3.300	1.01	82.80	82.00	80.00	0.78	0.76	0.74	600	275	275	0.01900
2.20	3.00	100L	1450	4.900	1.48	84.30	84.00	82.00	0.78	0.76	0.74	600	230	270	0.02800
3.00	4.00	112M	1450	7.200	2.02	86.30	85.00	83.50	0.78	0.75	0.72	650	225	275	0.05500
3.70	5.00	112M	1445	7.600	2.49	86.30	86.00	84.00	0.81	0.79	0.70	650	250	275	0.06500
4.50	6.00	112M	1440	8.100	3.04	86.30	85.50	83.00	0.82	0.80	0.72	650	200	250	0.08200
5.50	7.50	132S	1450	11.250	3.69	87.70	87.00	86.00	0.82	0.80	0.78	650	250	275	0.12000
7.50	10.00	132M	1455	14.880	5.02	88.70	88.00	86.50	0.80	0.74	0.70	650	225	275	0.13500
9.30	12.50	160M	1460	19.200	6.20	89.80	89.00	88.00	0.84	0.82	0.81	650	225	250	0.17000
11.00	15.00	160M	1462	21.710	7.33	89.80	89.00	88.00	0.85	0.83	0.80	650	225	260	0.23000
15.00	20.00	160L	1465	27.350	9.97	90.60	90.30	89.75	0.85	0.84	0.83	650	250	265	0.30000
18.50	25.00	180M	1469	34.500	12.27	91.20	90.50	89.00	0.85	0.84	0.83	650	250	250	0.50000

TECHNICAL SPECIFICATIONS



Efficiency Class : IE2 **Enclosure :** TEFC **Insulation Class :** F
Voltage : 415 (±10 %) V **Duty :** S1 **Temp. Rise :** Limited to class B
Frequency : 50 (±5 %) Hz **Cooling :** IC 411 **Ambient Temperature :** 40°C
Degree of protections : IP 55

Combined Variation of Voltage & Frequency : ±10 %

6 Pole / 1000 RPM

MOTOR RATING		FRAME SIZE	RATED SPEED (RPM)	RATED CURRENT (AMP.)	RATED TORQUE (KG.M.)	EFFICIENCY			POWER FACTOR			STARTING CURRENT % OF RATED CURRENT	STARTING TORQUE % OF RATED TORQUE	PULL OUT TORQUE % OF RATED TORQUE	GD ² (KGM ²)
kW	HP					FL	¾L	½L	FL	¾L	½L				
0.18	0.25	71	890	0.900	0.20	57.00	55.00	53.00	0.60	0.55	0.50	450	200	200	0.00400
0.25	0.33	71	895	1.000	0.27	62.00	61.00	58.00	0.65	0.58	0.53	475	200	200	0.00450
0.37	0.50	80	900	1.200	0.40	67.60	67.00	65.00	0.70	0.62	0.52	480	210	210	0.00500
0.55	0.75	80	910	1.740	0.59	73.50	72.50	68.00	0.70	0.60	0.50	500	220	240	0.00800
0.75	1.00	90S	920	2.150	0.79	75.90	75.00	72.00	0.72	0.62	0.55	450	200	240	0.01200
1.10	1.50	90L	930	2.999	1.15	78.10	77.50	74.00	0.72	0.60	0.52	450	190	225	0.01600
1.50	2.00	100L	935	3.900	1.56	79.80	79.00	75.00	0.72	0.62	0.55	500	200	240	0.02500
2.20	3.00	112M	940	5.560	2.28	81.80	80.00	79.00	0.73	0.63	0.60	550	200	250	0.06500
3.00	4.00	132S	950	7.910	3.08	84.30	82.00	81.00	0.68	0.62	0.55	550	200	250	0.01100
3.70	5.00	132S	950	8.520	3.79	84.30	83.00	81.50	0.73	0.70	0.60	650	200	250	0.01300
5.50	7.50	132M	960	11.950	5.58	86.00	84.00	81.50	0.74	0.70	0.61	550	200	240	0.18000
7.50	10.00	160M	960	16.000	7.61	87.20	87.00	85.00	0.78	0.74	0.66	600	200	240	0.29000
9.30	12.50	160L	970	20.450	9.34	88.70	88.00	84.00	0.78	0.75	0.65	550	200	225	0.35000
11.00	15.00	160L	965	22.350	11.10	88.70	88.00	86.00	0.79	0.76	0.68	600	200	270	0.40000
15.00	20.00	180L	965	30.800	15.14	89.70	89.00	88.00	0.80	0.75	0.65	650	250	250	0.82000
18.50	25.00	200L	970	35.850	18.58	90.40	90.00	88.00	0.81	0.75	0.67	625	240	250	1.20000



TECHNICAL SPECIFICATIONS

Efficiency Class : IE2 **Enclosure :** TEFC **Insulation Class :** F
Voltage : 415 (±10 %) V **Duty :** S1 **Temp. Rise :** Limited to class B
Frequency : 50 (±5 %) Hz **Cooling :** IC 411 **Ambient Temperature :** 40°C
Degree of protections : IP 55

8 Pole / 750 RPM

Combined Variation of Voltage & Frequency : ±10 %

MOTOR RATING		FRAME SIZE	RATED SPEED (RPM)	RATED CURRENT (AMP.)	RATED TORQUE (KG.M.)	EFFICIENCY			POWER FACTOR			STARTING CURRENT % OF RATED CURRENT	STARTING TORQUE % OF RATED TORQUE	PULL OUT TORQUE % OF RATED TORQUE	GD ² (KGM ²)
kW	HP					FL	¾L	½L	FL	¾L	½L				
0.18	0.25	80	650	0.950	0.27	46.00	45.00	42.00	0.62	0.55	0.50	500	175	200	0.00600
0.25	0.33	80	650	1.150	0.37	51.00	50.00	48.00	0.64	0.62	0.58	500	180	200	0.00800
0.37	0.50	90S	660	1.500	0.55	56.10	55.50	54.00	0.65	0.63	0.57	500	175	225	0.01000
0.55	0.75	90L	670	2.100	0.80	61.70	59.50	56.00	0.66	0.64	0.54	500	170	225	0.01500
0.75	1.00	100L	670	2.600	1.09	66.20	65.00	64.00	0.66	0.64	0.55	500	175	225	0.02200
1.10	1.50	100L	675	3.500	1.59	70.80	69.00	65.00	0.66	0.63	0.53	500	175	240	0.06000
1.50	2.00	112M	680	4.400	2.15	74.10	73.50	72.00	0.65	0.62	0.60	500	175	240	0.06300
2.20	3.00	132S	690	6.000	3.11	77.60	75.50	73.00	0.68	0.63	0.59	500	180	250	0.11000
3.00	4.00	160M	700	8.750	4.17	81.40	79.00	77.00	0.65	0.62	0.59	500	190	250	0.35000
3.70	5.00	160M	700	9.800	5.15	81.40	80.00	79.00	0.66	0.64	0.60	550	180	240	0.42000
5.50	7.50	160M	710	13.500	7.55	83.80	82.00	80.00	0.70	0.65	0.62	550	175	240	0.48000
7.50	10.00	160L	710	17.500	10.29	85.30	84.00	81.00	0.78	0.70	0.65	550	200	250	0.60000
11.00	15.00	180L	710	23.800	15.09	86.90	85.00	82.00	0.77	0.70	0.64	550	200	250	0.80000
15.00	20.00	200L	715	33.000	20.43	88.00	86.00	81.00	0.78	0.72	0.66	550	200	250	1.10000
18.50	25.00	225S	720	43.000	25.03	88.60	86.50	81.50	0.80	0.74	0.68	550	200	250	1.70000

INDUCTION MOTOR

IE3 3 PHASE

ELECTRA series



RANGE AVAILABLE

OUTPUT : 0.18 kW to 18.5 kW (0.25 HP to 25.0 HP)

FRAME SIZE : 63 to 200 L

POLES : 2, 4 & 6

TECHNICAL SPECIFICATION

STANDARD PRODUCT

OPTIONS AVAILABLE

	STANDARD PRODUCT	OPTIONS AVAILABLE
Degree of Protection	IP 55	IP 56
Insulation Class	F	H
Temperature Rise	Limited to class B	F
Rated Voltage	415 Volt (± 10 %)	230 Volt
Rated Frequency	50 Hz (± 5 %)	60 Hz
Enclosure	Totally Enclosed Fan Cooled (TEFC)	-
Mounting	Foot, Flange (B - Type & C- Type)	it's Combination (refer Mounting details for Mounting arrangement)
Duty	S1	-
Maximum Ambient Temp.	40° C	50° C
Altitude	Up to 1000 MASL(Meter above Sea Level)	-
Cooling Method	IC 411	IC 410
Paint Colour	Black	on Request
Fan Cover	Sheet Metal	-
Terminal Box Position	Top	Left hand side(LHS), Right hand side (RHS)
Shaft Extension	Single	Duel
Brake provision	-	on Request

Note: On request of optional features, Minimum Order Quantity may be applicable & Lead time may vary from standard product, for more information please contact our branch Office.

THREE PHASE INDUCTION MOTORS

TECHNICAL SPECIFICATIONS

Efficiency Class : IE3	Enclosure : TEFC	Insulation Class	: F
Voltage : 415 (±10 %) V	Duty : S1	Temp. Rise	: Limited to class B
Frequency : 50 (±5 %) Hz	Cooling : IC 411	Ambient Temperature	: 40°C
		Degree of protections	: IP 55



Combined Variation of Voltage & Frequency : ±10 %

2 Pole / 3000 RPM

MOTOR RATING		FRAME SIZE	RATED SPEED (RPM)	RATED CURRENT (AMP.)	RATED TORQUE (KG.M.)	EFFICIENCY			POWER FACTOR			STARTING CURRENT % OF RATED CURRENT	STARTING TORQUE % OF RATED TORQUE	PULL OUT TORQUE % OF RATED TORQUE	GD ² (KGM ²)
KW	HP					FL	¾L	½L	FL	¾L	½L				
0.18	0.25	63	2770	0.800	0.06	65.90	64.50	62.00	0.50	0.48	0.45	600	180	200	0.00150
0.25	0.33	63	2780	0.900	0.09	69.70	67.50	63.00	0.55	0.53	0.49	600	185	200	0.00175
0.37	0.50	71	2800	1.100	0.13	73.80	72.50	71.50	0.75	0.72	0.66	600	200	220	0.00180
0.55	0.75	71	2800	1.400	0.19	77.80	77.00	76.00	0.78	0.73	0.67	600	200	250	0.00210
0.75	1.00	80	2830	1.800	0.26	80.70	80.00	76.50	0.80	0.78	0.70	650	210	225	0.00350
1.10	1.50	80	2840	2.500	0.38	82.70	82.00	79.50	0.83	0.79	0.70	650	250	275	0.01000
1.50	2.00	90S	2860	3.100	0.51	84.20	83.75	82.75	0.85	0.82	0.73	650	250	275	0.01300
2.20	3.00	90L	2880	4.250	0.74	85.90	85.50	84.00	0.87	0.83	0.72	700	225	275	0.01600
3.70	5.00	100L	2890	7.250	1.25	87.80	87.00	86.00	0.86	0.83	0.75	700	250	275	0.02100
5.50	7.50	132S	2910	10.250	1.84	89.20	88.50	87.50	0.88	0.85	0.78	700	250	275	0.12000
7.50	10.00	132S	2910	13.800	2.51	90.10	89.75	88.50	0.86	0.84	0.79	700	225	250	0.14000
9.30	12.50	160M	2935	17.200	3.09	91.20	90.25	89.50	0.88	0.84	0.75	650	225	275	0.18000
11.00	15.00	160M	2935	20.200	3.65	91.20	90.90	90.00	0.87	0.84	0.78	700	235	275	0.22000
15.00	20.00	160M	2940	26.900	4.97	91.90	91.25	90.00	0.88	0.85	0.80	700	250	275	0.30000
18.50	25.00	160L	2945	32.400	6.12	92.40	92.00	90.50	0.88	0.86	0.78	650	250	275	0.35000



TECHNICAL SPECIFICATIONS

Efficiency Class : IE3	Enclosure : TEFC	Insulation Class	: F
Voltage : 415 (±10 %) V	Duty : S1	Temp. Rise	: Limited to class B
Frequency : 50 (±5 %) Hz	Cooling : IC 411	Ambient Temperature	: 40°C
		Degree of protections	: IP 55

4 Pole / 1500 RPM

Combined Variation of Voltage & Frequency : ±10 %

MOTOR RATING		FRAME SIZE	RATED SPEED (RPM)	RATED CURRENT (AMP.)	RATED TORQUE (KG.M.)	EFFICIENCY			POWER FACTOR			STARTING CURRENT % OF RATED CURRENT	STARTING TORQUE % OF RATED TORQUE	PULL OUT TORQUE % OF RATED TORQUE	GD ² (KGM ²)
KW	HP					FL	¾L	½L	FL	¾L	½L				
0.18	0.25	63	1380	0.800	0.13	69.90	69.00	67.00	0.64	0.61	0.55	550	190	210	0.00280
0.25	0.33	71	1390	0.900	0.18	73.50	73.00	70.00	0.68	0.65	0.57	550	190	220	0.00330
0.37	0.50	71	1410	1.100	0.26	77.30	76.50	73.00	0.70	0.68	0.60	600	180	230	0.00350
0.55	0.75	80	1420	1.400	0.38	80.80	79.50	77.00	0.74	0.71	0.62	600	200	225	0.00880
0.75	1.00	80	1430	1.900	0.51	82.50	82.00	81.50	0.77	0.75	0.62	550	225	275	0.01500
1.10	1.50	90S	1430	2.500	0.75	84.10	84.00	82.50	0.80	0.78	0.69	600	250	275	0.01700
1.50	2.00	90L	1435	3.450	1.02	85.30	84.50	83.00	0.80	0.78	0.72	600	250	275	0.02300
2.20	3.00	100L	1440	4.600	1.49	86.70	86.00	84.00	0.77	0.74	0.62	700	250	275	0.02800
3.70	5.00	112M	1450	7.800	2.49	88.40	88.00	87.00	0.79	0.77	0.70	675	250	275	0.06500
4.50	6.00	112M	1440	8.100	3.04	88.40	87.50	86.00	0.80	0.78	0.68	675	200	250	0.09200
5.50	7.50	132S	1455	10.950	3.68	89.60	89.25	88.50	0.80	0.78	0.72	650	240	275	0.13800
7.50	10.00	132M	1460	14.500	5.00	90.40	90.00	89.50	0.81	0.79	0.71	675	240	275	0.19000
9.30	12.50	160M	1470	18.350	6.16	91.40	89.50	88.00	0.80	0.77	0.69	675	250	275	0.33000
11.00	15.00	160M	1465	21.000	7.31	91.40	90.00	89.25	0.82	0.79	0.72	675	250	275	0.36500
15.00	20.00	160L	1470	29.000	9.94	92.10	91.50	90.00	0.83	0.79	0.71	675	250	275	0.50000
18.50	25.00	180M	1470	34.200	12.26	92.60	92.00	90.50	0.87	0.84	0.77	675	225	250	0.74000

TECHNICAL SPECIFICATIONS

Efficiency Class : IE3 **Enclosure :** TEFC **Insulation Class :** F
Voltage : 415 (±10 %) V **Duty :** S1 **Temp. Rise :** Limited to class B
Frequency : 50 (±5 %) Hz **Cooling :** IC 411 **Ambient Temperature :** 40°C
Degree of protections : IP 55



Combined Variation of Voltage & Frequency : ±10 %

6 Pole / 1000 RPM

MOTOR RATING		FRAME SIZE	RATED SPEED (RPM)	RATED CURRENT (AMP.)	RATED TORQUE (KG.M.)	EFFICIENCY			POWER FACTOR			STARTING CURRENT % OF RATED CURRENT	STARTING TORQUE % OF RATED TORQUE	PULL OUT TORQUE % OF RATED TORQUE	GD ² (KGM ²)
kW	HP					FL	¾L	½L	FL	¾L	½L				
0.18	0.25	71	900	0.900	0.19	64.00	62.50	59.00	0.59	0.54	0.50	550	170	200	0.00500
0.25	0.33	71	910	1.000	0.27	68.60	67.50	62.00	0.65	0.60	0.53	550	180	205	0.00600
0.37	0.50	80	920	1.200	0.39	73.50	72.50	70.00	0.68	0.64	0.56	500	190	210	0.00920
0.55	0.75	80	920	1.700	0.58	77.20	75.50	71.00	0.71	0.67	0.59	550	190	215	0.01000
0.75	1.00	90S	935	2.100	0.78	78.90	78.00	76.50	0.72	0.67	0.58	500	195	220	0.01700
1.10	1.50	90L	945	3.200	1.13	81.00	79.50	77.00	0.74	0.69	0.61	500	200	225	0.02500
1.50	2.00	100L	940	3.800	1.55	82.50	81.50	79.50	0.73	0.65	0.59	500	225	230	0.02800
2.20	3.00	112M	950	5.250	2.26	84.30	83.50	82.00	0.75	0.70	0.65	550	225	250	0.07200
3.70	5.00	132S	960	8.600	3.75	86.50	85.50	82.00	0.80	0.76	0.68	600	180	225	0.20000
5.50	7.50	132M	960	12.500	5.58	88.00	87.00	86.00	0.79	0.76	0.65	550	190	225	0.27500
7.50	10.00	160M	965	15.500	7.57	89.10	88.50	86.50	0.78	0.75	0.69	600	225	250	0.44000
9.30	12.50	160L	975	20.600	9.29	90.30	89.25	88.50	0.78	0.75	0.69	600	225	275	0.55000
11.00	15.00	160L	970	22.700	11.05	90.30	89.75	89.00	0.80	0.77	0.71	650	225	275	0.65000
15.00	20.00	180L	970	30.550	15.06	91.20	90.75	89.75	0.82	0.77	0.72	600	240	240	1.15000
18.50	25.00	200L	970	35.300	18.58	91.70	91.25	90.75	0.86	0.82	0.74	650	225	250	1.78000

INDUCTION MOTOR

⚡ 1 PHASE



RANGE AVAILABLE

OUTPUT : 0.18 kW to 2.2 kW (0.25 HP to 3.0 HP)

FRAME SIZE : 71 to 112M

POLES : 2 - C. S. & R. | 4 - C. S. & C. R.

TECHNICAL SPECIFICATION

STANDARD PRODUCT

OPTIONS AVAILABLE

	STANDARD PRODUCT	OPTIONS AVAILABLE
Insulation Class	F	-
Rated Voltage	230 Volt (± 6 %)	-
Rated Frequency	50 Hz (± 3 %)	-
Enclosure	Totally Enclosed Fan Cooled (TEFC)	-
Mounting Type	Foot, Flange (B - Type & C- Type)	it's Combination (refer Mounting details for Mounting arrangement)
Duty	S1	-
Maximum Ambient Temp.	40° C	-
Altitude	Up to 1000 MASL(Meter above Sea Level)	-
Cooling Method	IC 411	IC410
Direction of Rotation	CW (view from Driving End Side)	CCW
Degree of Protection	IP 44	IP 55
Paint Colour	Black	on Request
Fan Cover	Sheet Metal	
Terminal Box Position	Top	Left hand side(LHS), Right hand side (RHS)

Note: On request of optional features, Minimum Order Quantity may be applicable & Lead time may vary from standard product, for more information please contact our branch Office.

SINGLE PHASE INDUCTION MOTORS

TECHNICAL SPECIFICATIONS

Motor Type : C. S. & C. R. **Enclosure** : TEFC **Insulation Class** : F
Voltage : 230 (±6%) V **Duty** : S1 **Cooling** : IC411
Frequency : 50 (±3%) Hz **Ambient Temperature** : 40 °C

1 PHASE

4 Pole / 1500 RPM

MOTOR RATING		FRAME SIZE	RATED SPEED (RPM)	RATED CURRENT (AMP.)	RATED TORQUE (KG.M.)	EFFICIENCY			POWER FACTOR			STARTING CURRENT % OF RATED CURRENT	STARTING TORQUE % OF RATED TORQUE	RUNNING CAPACITOR (µFD)	STARTING CAPACITOR (µFD)*	PULL OUT TORQUE % OF RATED TORQUE
kW	HP					FL	¾L	½L	FL	¾L	½L					
0.18	0.25	80	1450	1.55	0.12	63.00	62.00	60.00	0.80	0.78	0.70	575	275	6.0	60/80	275
0.37	0.50	80	1440	3.40	0.25	65.00	62.00	58.00	0.79	0.73	0.63	500	275	12.5	60/80	250
0.55	0.75	80	1445	4.20	0.37	68.00	62.00	52.00	0.91	0.88	0.80	500	230	15.0	100/120	225
0.75	1.00	90S	1450	6.70	0.50	72.00	68.00	55.00	0.75	0.65	0.55	475	250	15.0	120/150	210
1.10	1.50	90L	1455	7.80	0.74	75.00	71.00	64.00	0.85	0.80	0.68	525	240	25.0	150/200	210
1.50	2.00	100L	1460	9.10	1.00	79.00	78.00	75.00	0.91	0.87	0.81	500	250	30.0	200/250	275
2.20	3.00	112M	1460	12.50	1.47	81.00	79.00	75.00	0.95	0.93	0.90	550	275	36.0	280/350	275

MOUNTING DETAILS

MOUNTING POSITIONS

HORIZONTAL MOUNTING

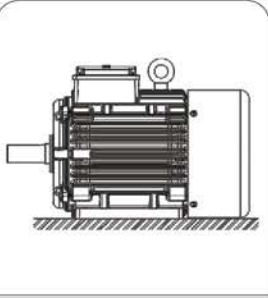

IM B3

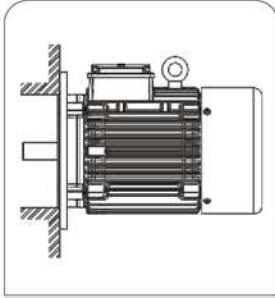

IM B5

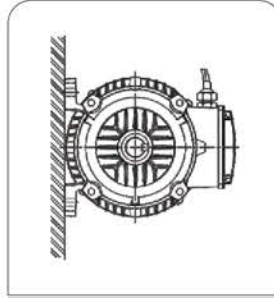

IM B6

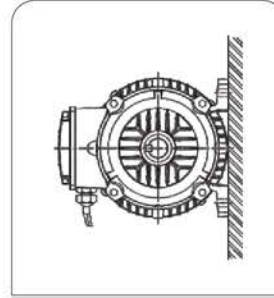

IM B7



IM B8

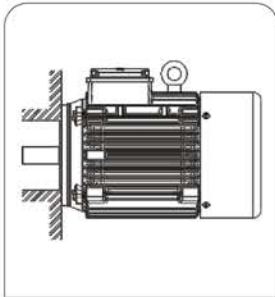

IM B14

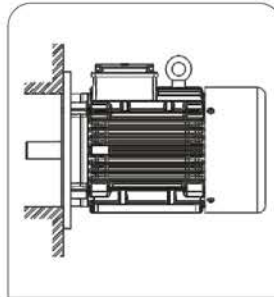

IM B35

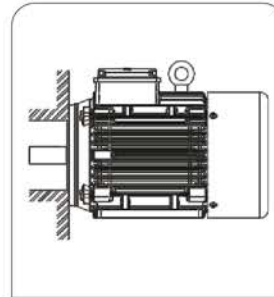

IM B34

VERTICAL MOUNTING

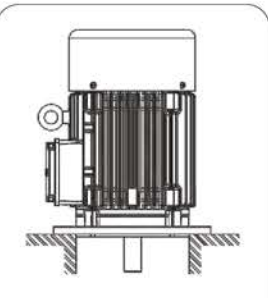

IM V1

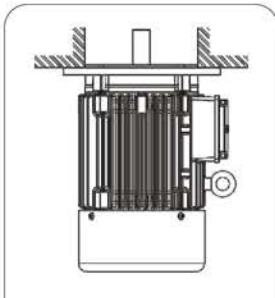

IM V3

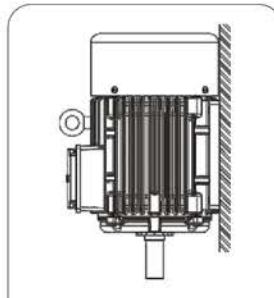

IM V5

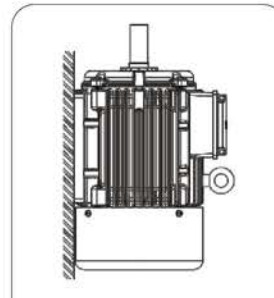

IM V6

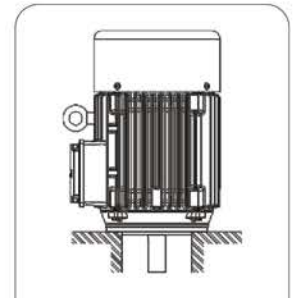

IM V18

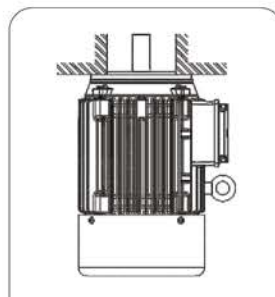

IM V19

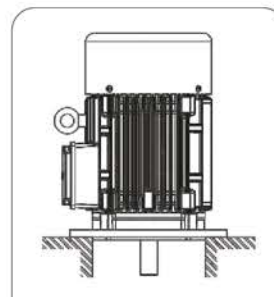

IM V15

DIMENSIONS OF FOOT MOUNTED MOTORS (B3) - CAST IRON

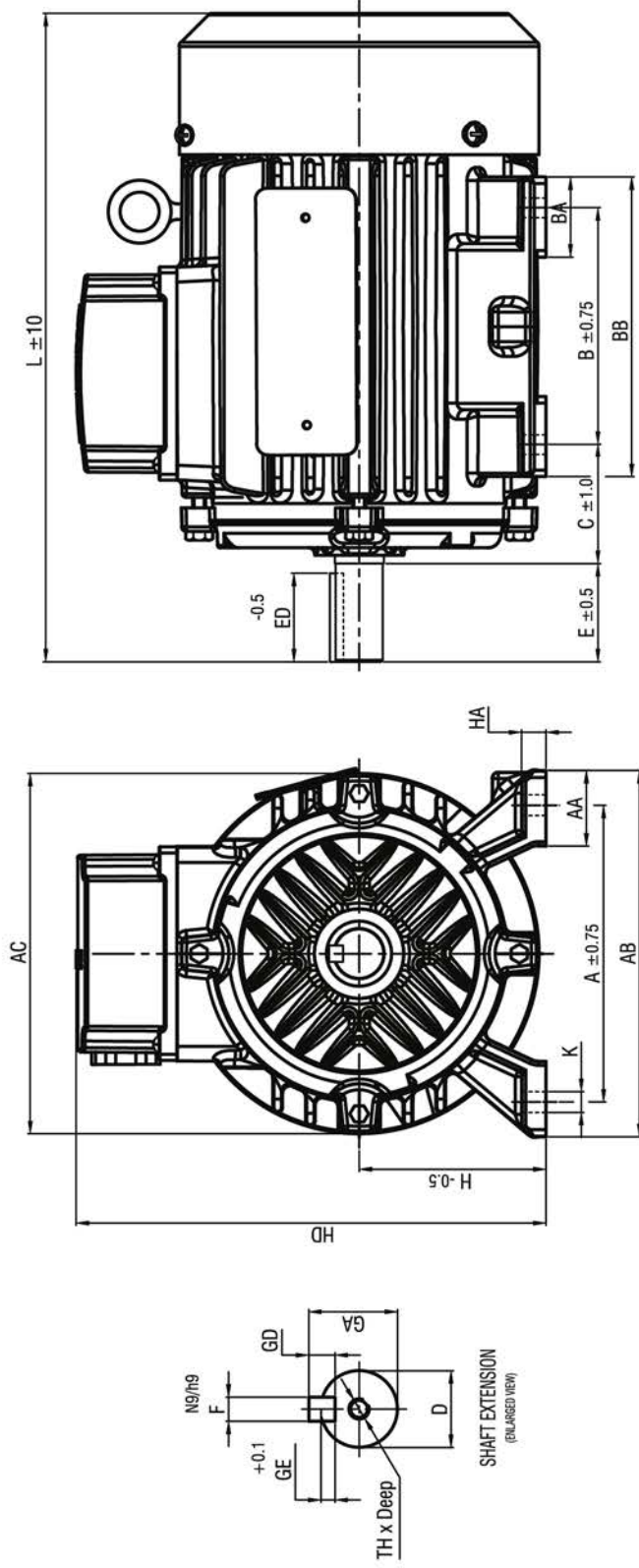

FRAME SIZE	A	B	C	H	K	L	TH	AA	AB	AC	BB	BA	HA	HD	D	E	ED	F	GA	GD	GE	TOLERANCE IN MICRON (µm)		
																						D	K	GD
63	100	80	40	63	7	210	M4X10	25	123	122	101	27	8	159	11	23	20	4	12.5	4	2.5	+8	-25	
71	112	90	45	71	7	244	M5X13	30	135	140	113	30	10	178	14	30	28	5	16	5	3	-3	+360	
80	125	100	50	80	10	275	M6X20	35	155	160	128	41	10	205	19	40	35	6	21.5	6	3.5			
90S	140	100	56	90	10	306	M8X20	35	170	177	128	41	12	225	24	50	45	8	27	7	4	+9		
90L	140	125	56	90	10	331	M8X20	35	170	177	153	45	12	225	24	50	45	8	27	7	4	-4		
100L	160	140	63	100	12	369	M10X20	44	197	200	183	55	13	249	28	60	55	8	31	7	4			
112M	190	140	70	112	12	400	M10X20	49	229	220	174	49	14	273	28	60	55	8	31	7	4			
132S	216	140	89	132	12	442	M12X25	57	258	258	186	49	18	316	38	80	70	10	41	8	5			
132M	216	178	89	132	12	480	M12X25	57	258	258	224	68	18	316	38	80	70	10	41	8	5	+430		
160M	254	210	108	160	15	606	M16X32	67	306	308	262	75	23	363	42	110	100	12	45	8	5	+18		
160L	254	254	108	160	15	650	M16X32	67	306	308	295	75	23	363	42	110	100	12	45	8	5	+2		
180M	279	241	121	180	15	660	M16X32	75	345	353	295	85	25	470	48	110	100	14	51.5	9	5.5			
180L	279	279	121	180	15	700	M16X32	75	345	353	335	85	25	470	48	110	100	14	51.5	9	5.5			
200L	318	305	133	200	19	770	M20X40	85	390	400	365	85	26	480	55	110	100	16	59	10	6	+30/+11	+520	

DIMENSIONS OF FLANGE MOUNTED MOTORS (B5) - CAST IRON

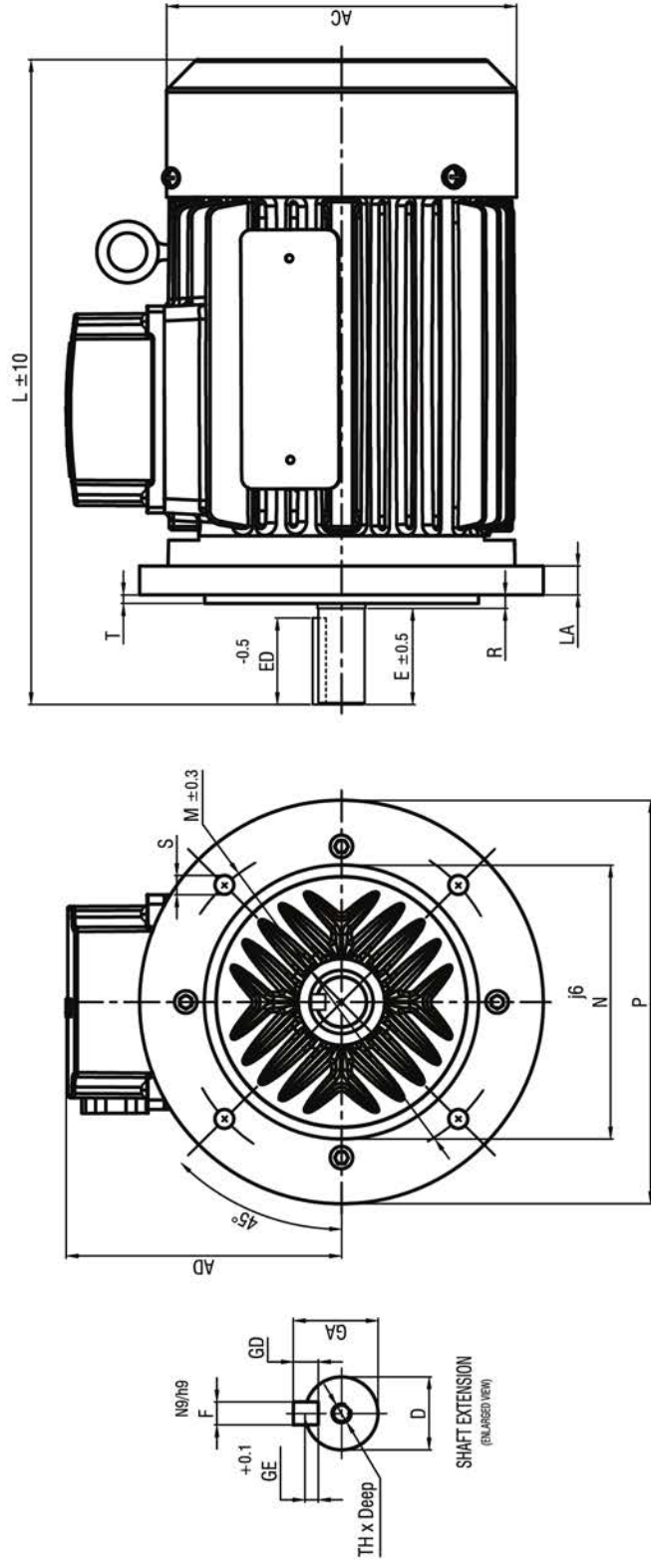

FRAME SIZE	M	N	P	S	NO. OF HOLES	T	LA	L	TH	AC	AD	R	D	E	ED	F	GA	GD	GE	TOLERANCE IN MICRON (μm)	
																				D	GD
63	115	95	140	10	4	3	10	210	M4X10	122	96	0	11	23	20	4	12.5	4	2.5	+8	-25
71	130	110	160	10	4	3.5	10	244	M5X13	140	107	0	14	30	28	5	16	5	3	-3	-30
80	165	130	200	12	4	3.5	10	275	M6X20	160	125	0	19	40	35	6	21.5	6	3.5	+9	-30
90S	165	130	200	12	4	3.5	10	315	M8X20	177	135	0	24	50	45	8	27	7	4	-4	-90
90L	165	130	200	12	4	3.5	10	345	M8X20	177	135	0	24	50	45	8	27	7	4	+18	-90
100L	215	180	250	15	4	4	11	369	M10X20	200	149	0	28	60	55	8	31	7	4	+2	-90
112M	215	180	250	15	4	4	11	400	M10X20	220	161	0	28	60	55	8	31	7	4	+18	-90
132S	265	230	300	15	4	4	12	442	M12X25	258	183	0	38	80	70	10	41	8	5	+2	-90
132M	265	230	300	15	4	4	12	480	M12X25	258	183	0	38	80	70	10	41	8	5	+18	-90
160M	300	250	350	19	4	5	13	606	M16X32	305	203	0	42	110	100	12	45	8	5	+2	-90
160L	300	250	350	19	4	5	13	650	M16X32	305	203	0	42	110	100	12	45	8	5	+18	-90

DIMENSIONS OF FOOT CUM FLANGE MOUNTED MOTORS - CAST IRON

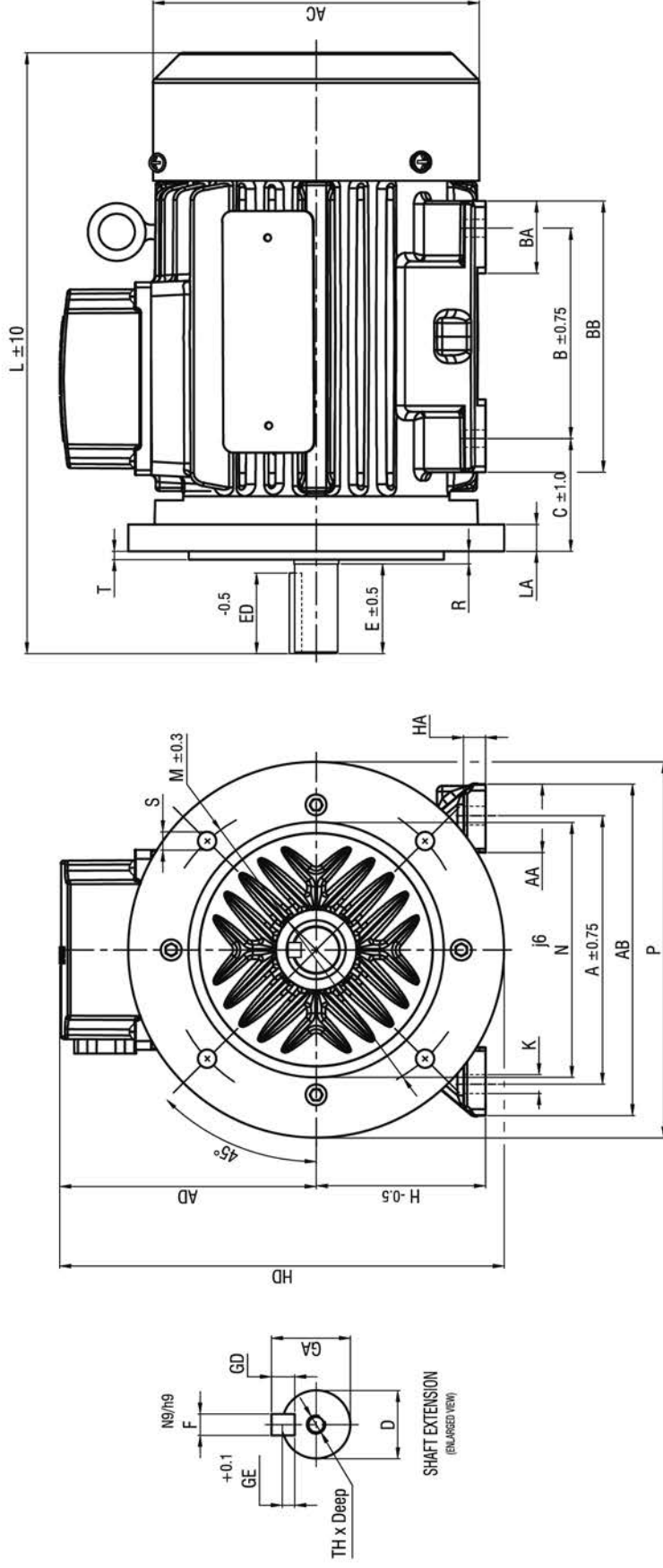

FRAME SIZE	A	B	C	H	K	M	N	P	S	NO. OF HOLES	T	LA	L	TH	AA	AB	BB	BA	HA	HD	AC	AD	R	D	E	ED	F	GA	GD	GE	TOLERANCE IN MICRON (μm)	
																															D	GD
63	100	80	40	63	7	115	95	140	10	4	3	10	210	M4X10	25	123	101	27	8	166	122	96	0	11	23	20	4	12.5	4	2.5	+8	-25
71	112	90	45	71	7	130	110	160	10	4	3.5	10	244	M5X13	30	135	113	30	10	187	140	107	0	14	30	28	5	16	5	3	-3	-30
80	125	100	50	80	10	165	130	200	12	4	3.5	10	275	M6X20	35	155	128	41	10	225	160	125	0	19	40	35	6	21.5	6	3.5	+9	-4
90S	140	100	56	90	10	165	130	200	12	4	3.5	10	315	M8X20	35	170	128	42	12	235	177	135	0	24	50	45	8	27	7	4	-4	-90
90L	140	125	56	90	10	165	130	200	12	4	3.5	10	345	M8X20	35	170	153	41	12	235	177	135	0	24	50	45	8	27	7	4	-4	-90
100L	160	140	63	100	12	215	180	250	15	4	4	11	369	M10X20	44	197	183	55	13	275	200	149	0	28	60	55	8	31	7	4	-4	-90
112M	190	140	70	112	12	215	180	250	15	4	4	11	400	M10X20	49	229	174	49	14	287	220	161	0	28	60	55	8	31	7	4	-4	-90
132S	216	140	89	132	12	265	230	300	15	4	4	12	442	M12X25	57	258	186	49	18	335	258	183	0	38	80	70	10	41	8	5	+18	+2
132M	216	178	89	132	12	265	230	300	15	4	4	12	480	M12X25	57	258	224	68	18	335	258	183	0	38	80	70	10	41	8	5	+18	+2

DIMENSIONS OF FOOT CUM FACE MOUNTED MOTORS - CAST IRON

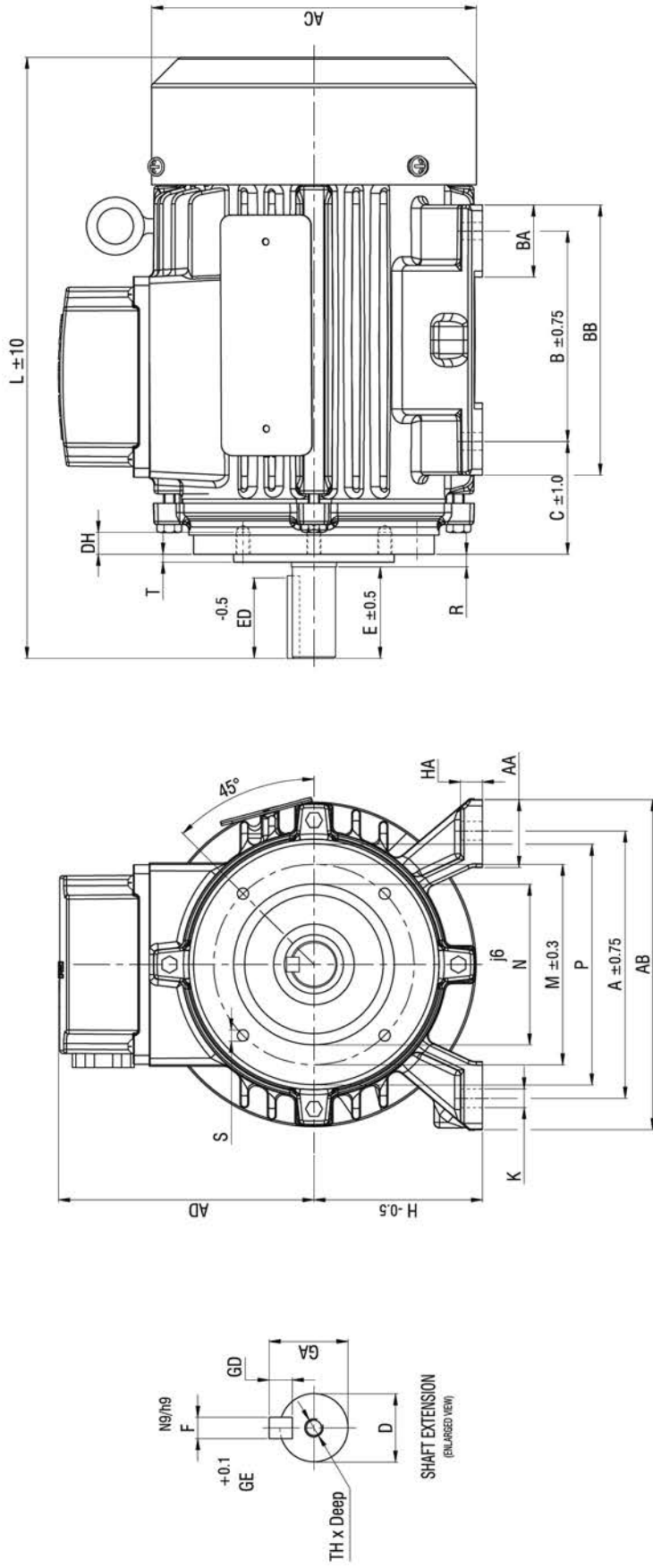

FRAME SIZE	A	B	C	H	K	M	N	P	S	NO. OF HOLES	T	LA	L	TH	AA	AB	BB	BA	HA	AC	AD	DH	R	D	E	ED	F	GA	GD	GE	TOLERANCE IN MICRON (µm)	
																													D	GD		
63	100	80	40	63	7	115	95	140	10	4	3	10	210	M4X10	25	123	101	27	8	122	96	8	0	11	23	20	4	12.5	4	2.5	+8	-25
71	112	90	45	71	7	130	110	160	10	4	3.5	10	244	M5X13	30	135	113	30	10	140	107	8	0	14	30	28	5	16	5	3	-3	-30
80	125	100	50	80	10	165	130	200	12	4	3.5	10	275	M6X20	35	155	128	41	10	160	125	10	0	19	40	35	6	21.5	6	3.5	+9	-4
90S	140	100	56	90	10	165	130	200	12	4	3.5	10	315	M8X20	35	170	128	42	12	177	135	10	0	24	50	45	8	27	7	4	-4	-90
90L	140	125	56	90	10	165	130	200	12	4	3.5	10	345	M8X20	35	170	153	41	12	177	135	10	0	24	50	45	8	27	7	4	+9	-4
100L	160	140	63	100	12	215	180	250	15	4	4	11	369	M10X20	44	197	183	55	13	200	149	10	0	28	60	55	8	31	7	4	+9	-4
112M	190	140	70	112	12	215	180	250	15	4	4	11	387	M10X20	49	229	174	49	14	220	161	10	0	28	60	55	8	31	7	4	+9	-4
132S	216	140	89	132	12	265	230	300	15	4	4	12	442	M12X25	57	258	186	49	18	258	183	12	0	38	80	70	10	41	8	5	+18	+2
132M	216	178	89	132	12	265	230	300	15	4	4	12	480	M12X25	57	258	224	68	18	258	183	12	0	38	80	70	10	41	8	5	+18	+2

DIMENSIONS OF FOOT MOUNTED MOTORS - ALUMINIUM

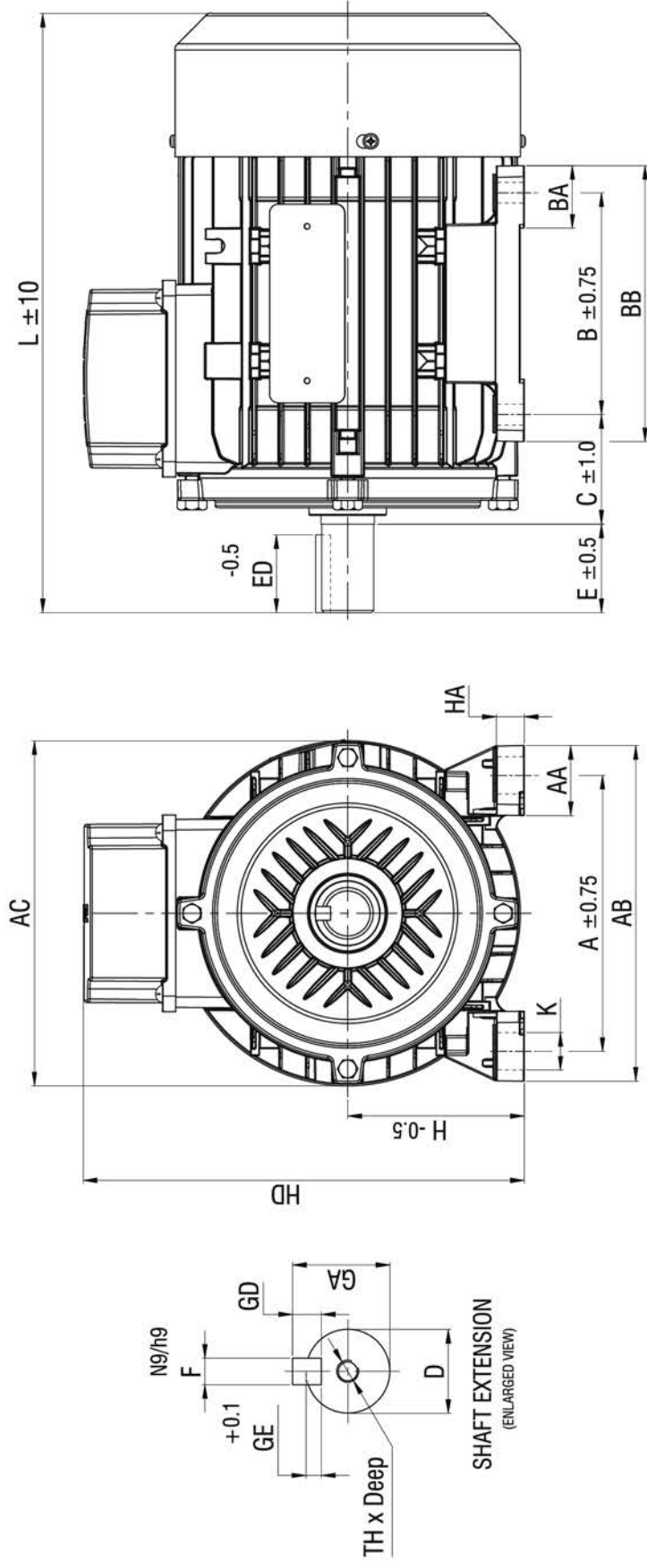

FRAME SIZE	TOLERANCE IN MICRON (μm)																							
	A	B	C	H	K	L	TH	AA	AB	AC	BB	BA	HA	HD	D	E	ED	F	GA	GD	GE	D	K	GD
63	100	80	40	63	13	212	M4X10	29	122	117	102	24	11	159	11	23	20	4	12.5	4	2.5	+8		-25
71	112	90	45	71	13	246	M5X13	30	137	134	108	26	12	174	14	30	28	5	16	5	3	-3		-30
80	125	100	50	80	17	274	M6X20	32	152	157	125	28	14	202	19	40	35	6	21.5	6	3.5	+9	+360	-90
90S	140	100	56	90	17	304	M8X20	35	169	172	129	29	13	217	24	50	45	8	27	7	4	-4		-90
90L	140	125	56	90	17	329	M8X20	35	169	172	154	31	13	217	24	50	45	8	27	7	4	-4		-90

DIMENSIONS OF FLANGE MOUNTED MOTORS - ALUMINIUM

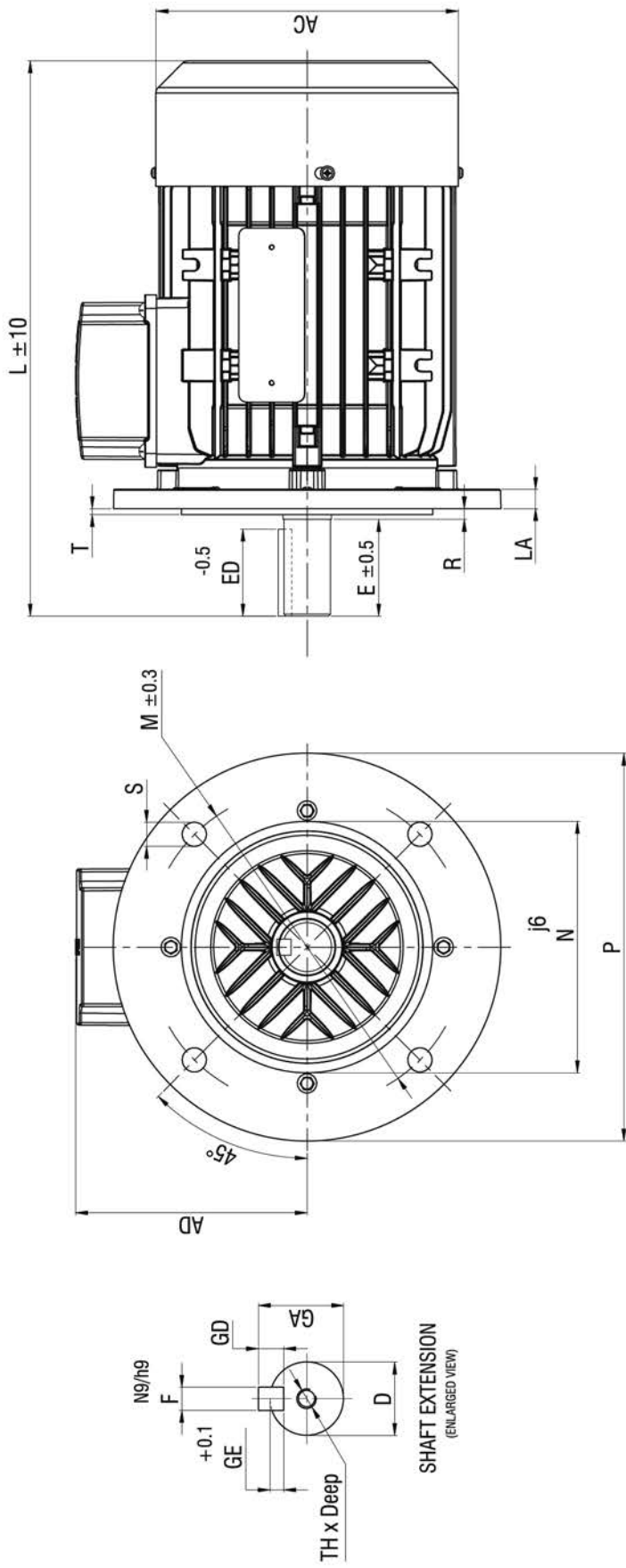

FRAME SIZE	M	N	P	S	NO. OF HOLES	T	LA	L	TH	AC	AD	R	D	E	ED	F	GA	GD	GE	TOLERANCE IN MICRON (µm)	
																				D	GD
63	115	95	140	10	4	3	9	212	M4X10	117	96	0	11	23	20	4	12.5	4	2.5	+8	-25
71	130	110	160	10	4	3.5	9	246	M5X13	134	103	0	14	30	28	5	16	5	3	-3	-30
80	165	130	200	12	4	3.5	10	274	M6X20	157	122	0	19	40	35	6	21.5	6	3.5	+9	-90
90S	165	130	200	12	4	3.5	10	304	M8X20	172	127	0	24	50	45	8	27	7	4	-4	-90
90L	165	130	200	12	4	3.5	10	329	M8X20	172	127	0	24	50	45	8	27	7	4	-4	-90

DIMENSIONS OF FOOT CUM FLANGE MOUNTED MOTORS - ALUMINIUM

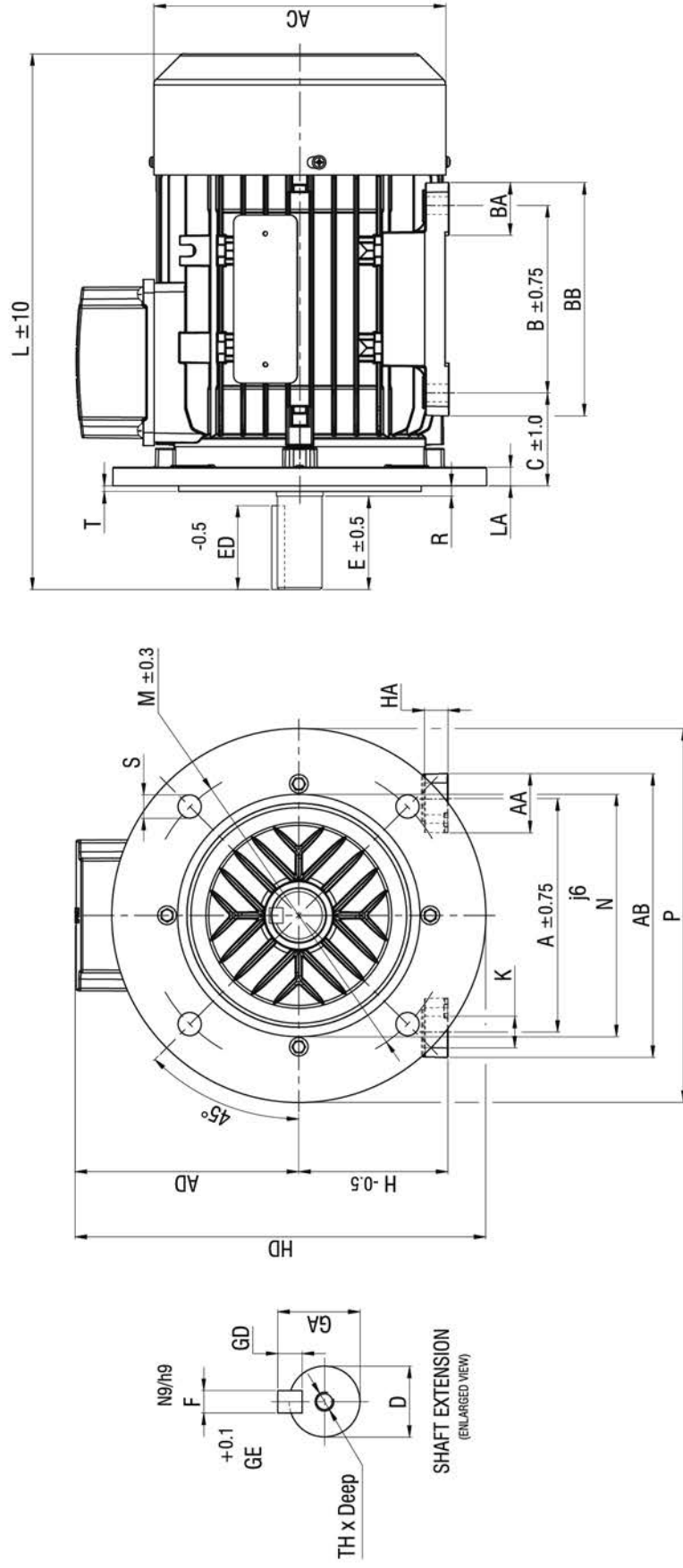

FRAME SIZE	NO. OF HOLES																			TOLERANCE IN MICRON (µm)												
	A	B	C	H	K	M	N	P	S	T	LA	L	TH	AA	AB	AC	BB	BA	HA	HD	AD	R	D	E	ED	F	GA	GD	GE	GD	D	GD
63	100	80	40	63	13	115	95	140	10	4	3	9	212	M4X10	29	122	117	102	24	11	166	96	0	11	23	20	4	12.5	4	2.5	+8	-25
71	112	90	45	71	13	130	110	160	10	4	3.5	9	246	M5X13	30	137	134	108	26	12	180	103	0	14	30	28	5	16	5	3	-3	-30
80	125	100	50	80	17	165	130	200	12	4	3.5	10	274	M6X20	32	157	157	125	28	14	220	122	0	19	40	35	6	21.5	6	3.5	+9	-4
90S	140	100	56	90	17	165	130	200	12	4	3.5	10	304	M8X20	35	172	172	129	29	13	227	127	0	24	50	45	8	27	7	4	-4	-90
90L	140	125	56	90	17	165	130	200	12	4	3.5	10	329	M8X20	35	172	172	154	31	13	227	127	0	24	50	45	8	27	7	4	-4	-90



INDUCTION MOTOR



EM

SERIES

INTRODUCTION

Crompech motor manufactures three phase asynchronous motors from 63 frame size to 112 frame in 4 pole and confirm to efficiency class IE2

VOLTAGE & FREQUENCY

The motors are suitable for 415 Voltage 10%, Frequency 50Hz 5% with 3 phase in Star connection.

The motors are suitable for 240 Voltage 10%, Frequency 50Hz 5% with 3 phase in delta connection.

INSULATION

The motor insulating materials (Enameled wire, Surface insulation treatments & impregnation type) are provided with class F & temperature rise limited to class B.

TYPE OF DUTY

S1 Duty (Continuous Duty) - The motor operated under rated condition continuously.

AMBIENT TEMPERATURE

All motors in our standard design are suitable for an ambient temperature from -15 °C to +50 °C and altitude above sea level 1000m. Motors can be used at ambient temperatures from 50 °C to 60 °C as long as the derating factors listed as below table are applied:

Ambient temperature (°C)	50°	55°	60°
% of rated power	100%	95%	90%

CONNECTION DIAGRAMS

STAR CONNECTION

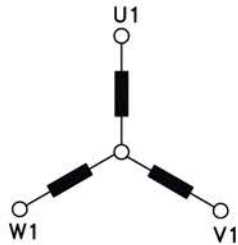

Input : Three Phase
415 volts / 50Hz

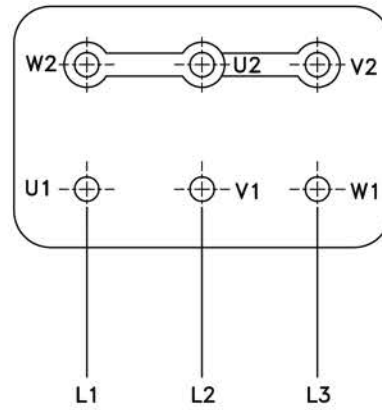

DELTA CONNECTION

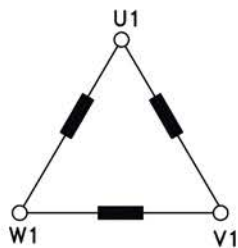

Input : Three Phase
240 volts / 50Hz

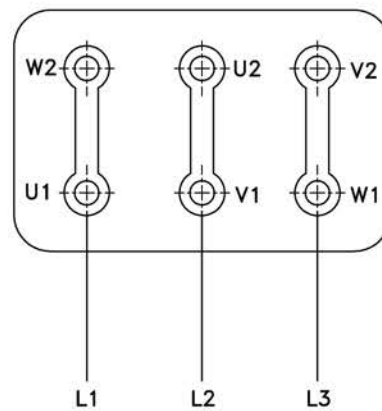

OUTLINE DIMENSIONS

B5

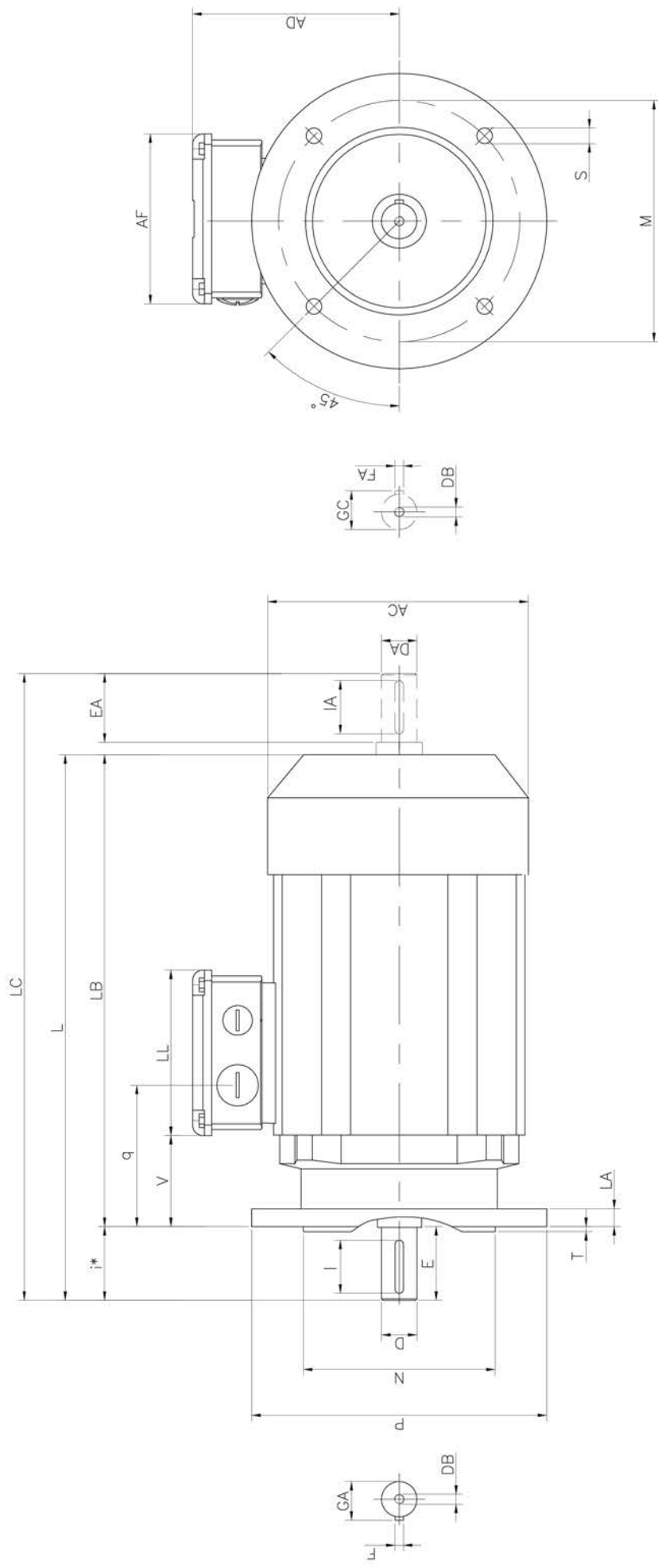

MECHANICAL DIMENSIONS (FLANGE MOUNTED MOTORS - B5)

Frame	FLANGE								SHAFT								OVERALL DIMENSIONS							
	N	M	P	S	T	i*	LA	D DA	E EA	GA GC	F FA	DB	I IA	AC	L	LB	LC	AD	LL	V	q	AF		
TM 63	95	115	140	9	3	23	10	11	23	12.5	4	M4	18	120	207	184	235	98	89	17	46	89		
TM 71	110	130	160	9	3.5	30	10	14	30	16	5	M5	25	139	230	200	266	109	89	23.5	53	89		
TM 80	130	165	200	11.5	3.5	40	11.5	19	40	21.5	6	M6	35	156	267	224	312	131	106	23	58	106		
TM 90 S	130	165	200	11.5	3.5	50	11.5	24	50	27	8	M8	40	172	292	242	347	136	106	25.5	60	106		
TM 90 L	130	165	200	11.5	3.5	50	11.5	24	50	27	8	M8	40	172	315	265	370	136	106	25.5	60	106		
TM 100	180	215	250	14	4	60	14	28	60	31	8	M10	50	196	372	297	437	145	106	32.5	69	106		
TM 112	180	215	250	14	4	60	15	28	60	31	8	M10	50	216	380	316	445	154	106	36	70	106		

Note : i Tolerance } up to length 85 mm ± 1mm Over 85 mm ± 1.5mm

B14

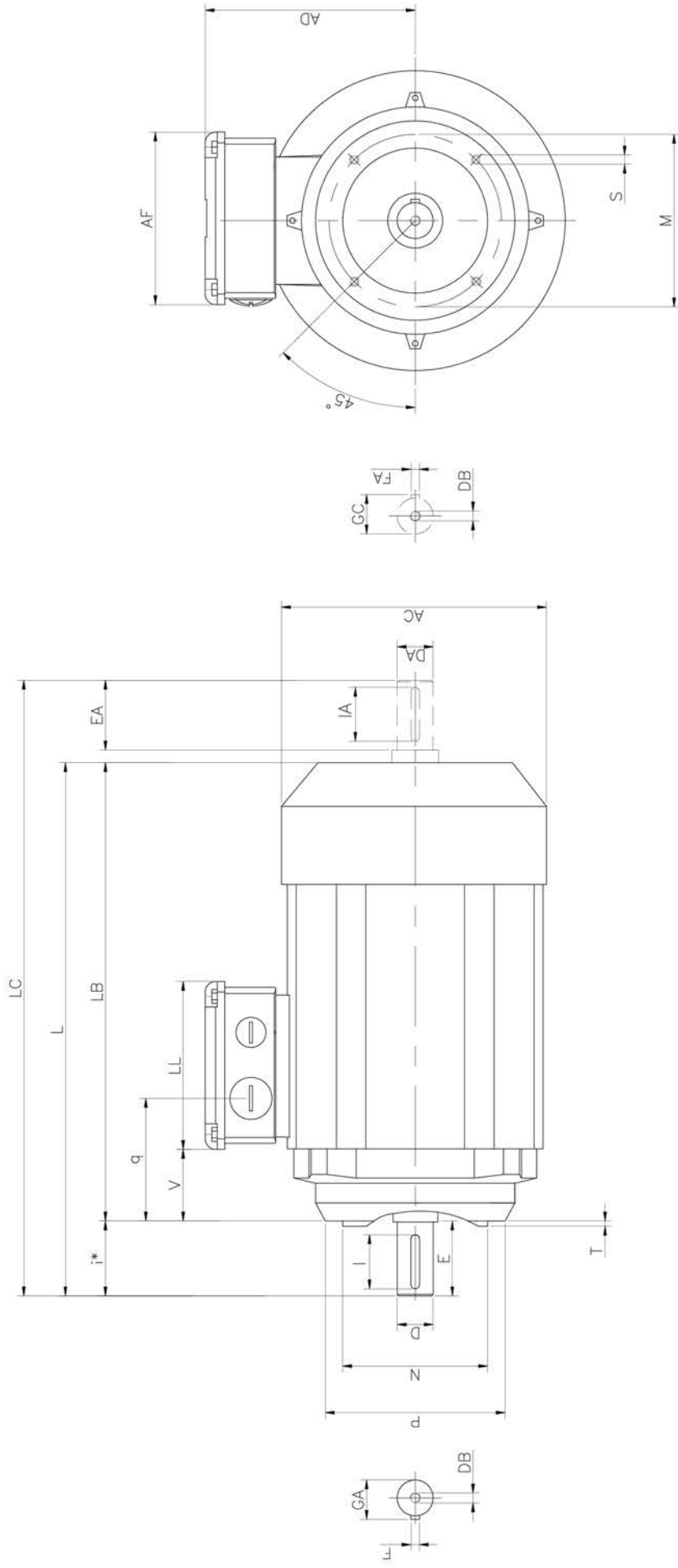

MECHANICAL DIMENSIONS (FLANGE MOUNTED MOTORS - B14)

Frame	FLANGE							SHAFT							OVERALL DIMENSIONS						
	N	M	P	S	T	i*	D DA	E EA	GA GC	F FA	DB	I IA	AC	L	LB	LC	AD	LL	V	q	AF
TM 63	60	75	90	M5x8	2.5	23	11	23	12.5	4	M4	18	120	207	184	235	98	89	17	46	89
TM 71	70	85	105	M6x10	2.5	30	14	30	16	5	M5	25	140	230	200	266	109	89	23.5	53	89
TM 80	80	100	120	M6x12	3	40	19	40	21.5	6	M6	35	156	267	224	312	131	106	23	58	106
TM 90 S	95	115	140	M8x15	3	50	24	50	27	8	M8	40	172	292	242	347	136	106	25.5	60	106
TM 90 L	95	115	140	M8x15	3	50	24	50	27	8	M8	40	172	315	265	370	136	106	25.5	60	106
TM 100	110	130	160	M8x15	3.5	60	28	60	31	8	M10	50	198	372	297	437	145	106	32.5	69	106
TM 112	110	130	160	M8x17	3.5	60	28	60	31	8	M10	50	217	380	316	445	154	106	36	70	106

Note : i Tolerance } up to length 85 mm ± 1mm Over 85 mm ± 1.5mm

MECHANICAL DIMENSIONS (FOOT MOUNTED MOTORS - B3)

Frame	SHAFT														OVERALL DIMENSIONS									
	A	B	HA	BB	AB	K	C	i*	H	D DA	E EA	GA GC	F FA	DB	I IA	AC	L	LB	LC	AD	LL	V	q	AF
TM 63	100	80	9.3	105	125	8	40	23	63	11	23	12.5	4	M4	18	120	207	184	235	98	89	17	46	89
TM 71	112	90	9.5	108	140	8	45	30	71	14	30	16	5	M5	25	140	230	200	266	109	89	23.5	53	89
TM 80	125	100	13	125	154	10.5	50	40	80	19	40	21.5	6	M6	35	156	267	227	312	131	106	23	58	106
TM 90 S	140	100	14	130	174	11.5	56	50	90	24	50	27	8	M8	40	172	292	242	347	136	106	25.5	60	106
TM 90 L	140	125	15	155	177	11.5	56	50	90	24	50	27	8	M8	40	172	315	272	370	136	106	25.5	60	106
TM 100	160	140	15	175	190	13	63	60	100	28	60	31	8	M10	50	198	372	312	437	145	106	32.5	69	106
TM 112	190	140	15	175	225	13	70	60	112	28	60	31	8	M10	50	217	380	320	445	154	106	36	70	106

Note : i Tolerance { up to length 85 mm ± 1mm Over 85 mm ± 1.5mm

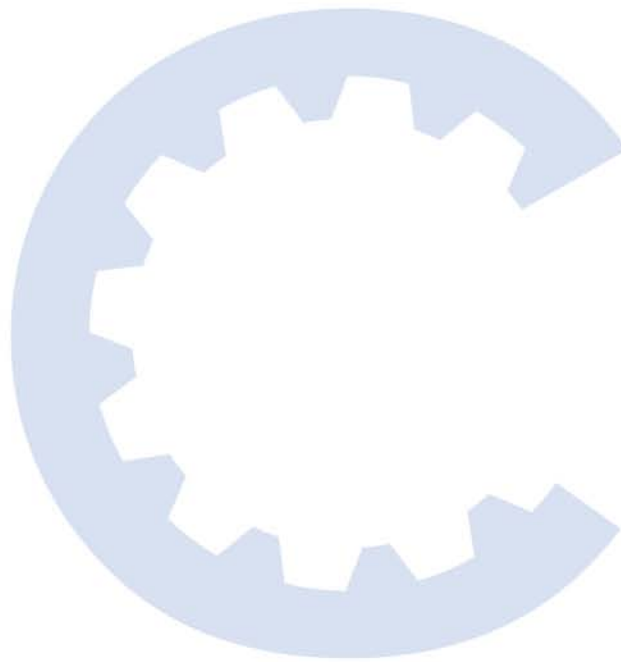

Plot No.7, Behind Vishal Furniture, Near Pooja Chemicals, Neptune Traders Street,
8-A National Highway, Morbi-2. Gujarat (INDIA). Pin Code: 363642

Office Cell : **+91 96623 77177** | Cell : **+91 99791 35272**

E-mail : info@crompechmotor.com
Web : www.crompechmotor.com